



EKSPLOATĀCIJAS ĪPAŠĪBU DEKLARĀCIJA

Dop Nr. KEW - 2323-CPR-0033 - lv

1. Produkta tipa unikālais identifikācijas kods: leskrūvējams stiprinājums TSBD / TSBDL / TSBD WS / TSBDX
2. Tipa, partijas vai sērijas numurs vai jebkurš cits elements, kas ļauj identificēt būvizstrādājumu, kā to pieprasa 11(4) pants: ETA-08/0314 pielikums A4
Partijas numurs: skatīt uz iepakojuma
3. Būvizstrādājuma paredzētais pielietojums saskaņā ar piemērojamo harmonizēto tehnisko specifikāciju, kā to paredzējis ražotājs:

vispārējs tips	leskrūvējams plastmasas enkurs ārējās siltumizolācijas kompozīta sistēmu ar apmetumu stiprināšanai
paredzēts lietošanai	ETA-08/0314 pielikums B1
iespēja / kategorija	ETA-08/0314 pielikums B1
ielādēšana	ETA-08/0314 pielikums B1
materiāls	ETA-08/0314 pielikums A10
temperatūras diapazons	ETA-08/0314 pielikums B1

4. Nosaukums, reģistrētais nosaukums vai reģistrētas tirdzniecības zīmes nosaukums un ražotāja kontaktadrese, kā to pieprasa 11(5). pants.
KEW Kunststoffzeugnisse GmbH Wilthen
Dresdener Straße 19
02681 Wilthen
Vācija
5. Ja piemēro, autorizētā pārstāvja, kas ir pilnvarots veikt 12(2) pantā norādītos uzdevumus, nosaukums un kontaktadrese:
--
6. Būvizstrādājuma īpašību nemainīguma novērtēšanas un verificācijas sistēma vai sistēmas, kā norādīts V pielikumā:
Sistēma 2+
7. Eksploatācijas īpašību deklarācijas attiecībā uz būvizstrādājumu, uz ko attiecas harmonizētais standarts, gadījumā:
--

8. Eksploatācijas īpašību deklarācijas, kas attiecas uz būvizrādājumu, kam izsniegts Eiropas tehniskais novērtējums, gadījumā:

ir izdota: **DIBt Deutsches Institut für Bautechnik**
ETA-08/0314 uz 15.04.2015
pamatojoties uz: **ETAG 014, 2011. gada februāra versija**
institūcija: **1109-CPR** izpildīja **Sistēma 2+**

- i) sākotnējā ražotnes apskate un ražošanas procesa kontrole
ii) nepārtraukta ražošanas procesa kontroles uzraudzība, novērtēšana un apstiprināšana

un tiek uzrādīts sekojošais: **1109-CPR-2002**

9. Deklarētās īpašības:

Būtiskie raksturlielumi	Projektēšanas metode	Eksploatācijas īpašības		Harmonizētā tehniskā specifikācija
		Elektrolītiski cinkots tērauds	nerūsējošais tērauds	
Raksturīgā noturība	EAD 330196-01-0604	ETA-08/0314 pielikums C1	ETA-08/0314 pielikums C1	EAD 330196-01-0604
Minimālais šķautnes attālums un enkuru savstarpējais attālums	EAD 330196-01-0604	ETA-08/0314 pielikums B2	ETA-08/0314 pielikums B2	
Nobīdes īpašības	EAD 330196-01-0604	ETA-08/0314 pielikums C2	ETA-08/0314 pielikums C2	
Punkta termiskā caurlaidība saskaņā ar	EAD 330196-01-0604	ETA-08/0314 pielikums C3-C5	ETA-08/0314 pielikums C3-C5	
Plātnes stingrība saskaņā ar	EAD 330196-01-0604	ETA-08/0314 pielikums C5	ETA-08/0314 pielikums C5	

Ja izmanto 37. vai 38. pantā norādīto speciālo tehnisko dokumentāciju – prasības, kurām atbilst produkts:

--

10. Produkta, kas identificēts 1. un 2. punktā, īpašības atbilst 9. punktā deklarētajām īpašībām.

Šī eksploatācijas īpašības deklarācija ir izdota ar pilnu ražotāja, kas identificēts 4. punktā, atbildību.

Ražotāja vārdā parakstīja:

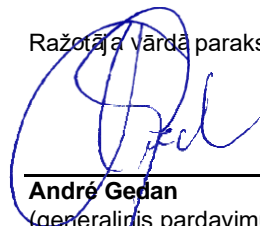

André Gedan
(generālis pārdavimū ir rinkodaros direktorius)
Wilthen, 20.04.2018



TSBD

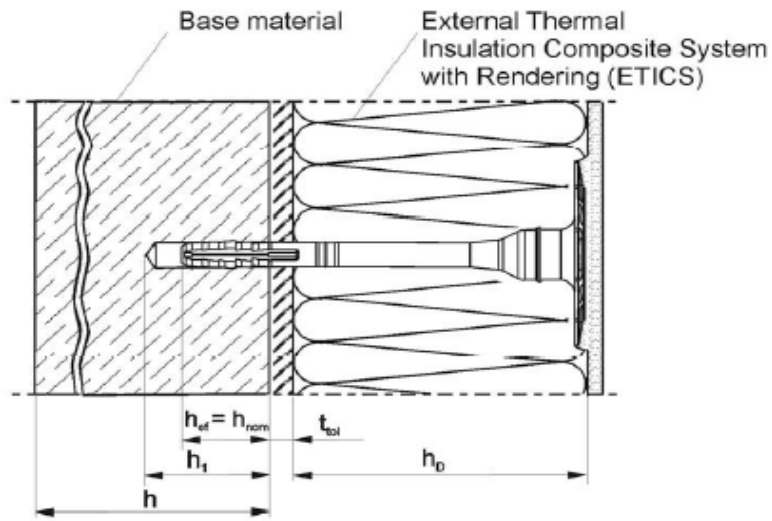

TSBDL

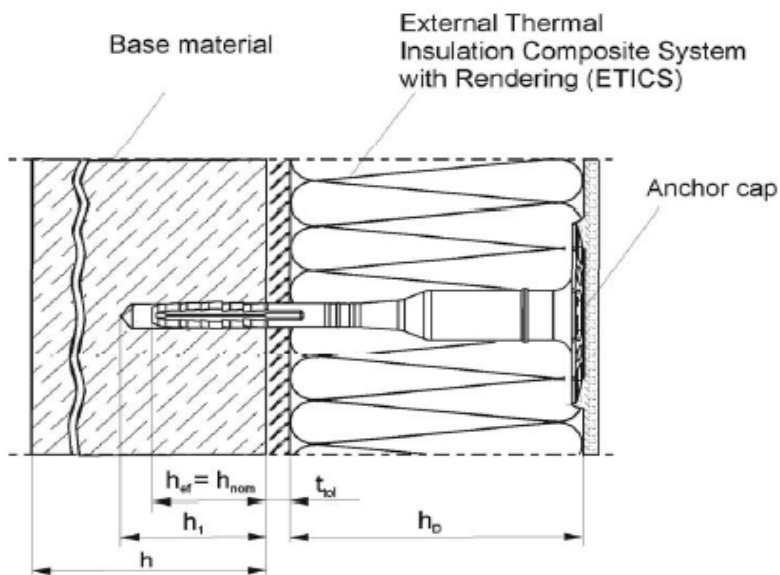

Insulation support · TSBD · TSBDL · TSBD WS · TSBD WSG

Product description
Intended use: TSBD, TSBDL

Annex A 1

**TSBD +
Insulation cover**

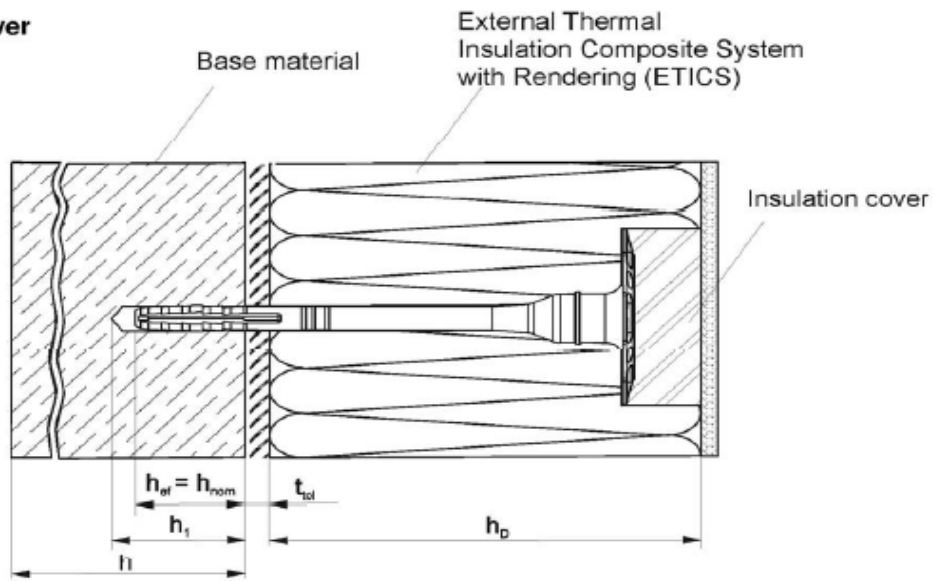

**TSBDL +
Insulation cover**

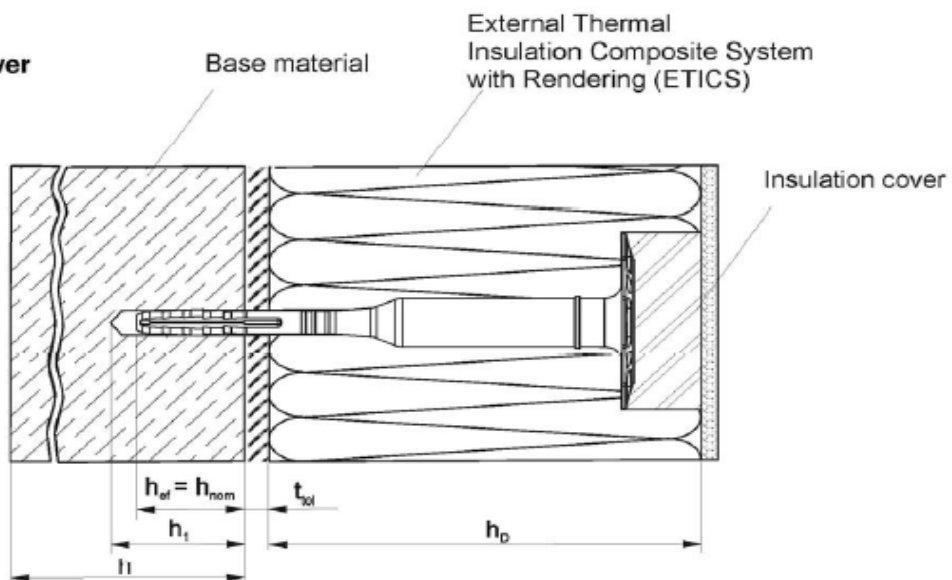

Insulation support · TSBD · TSBDL · TSBD WS · TSBD WSG

Product description

Installed condition with insulation cover: TSBD, TSBDL

Annex A 2

TSBD WS

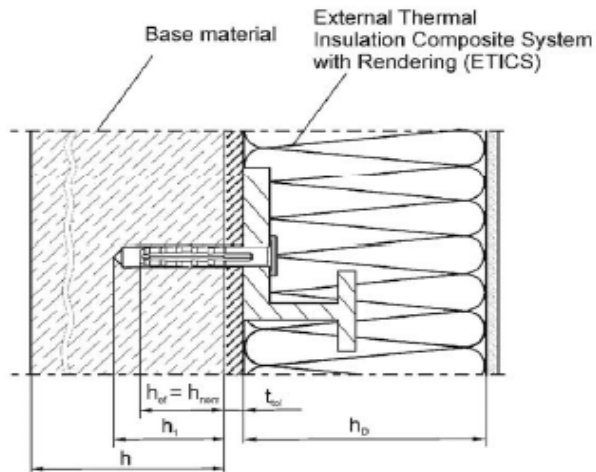

TSBD WSG

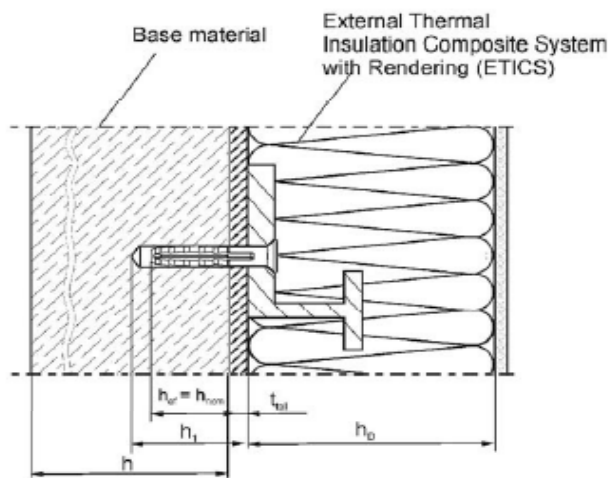

Legend

- h_{ef} = effective anchorage depth
- h_1 = depth of drilled hole to deepest point
- h = thickness of member (wall)
- h_D = thickness of insulation material
- t_{col} = thickness of equalizing layer or non-load bearing coating

Insulation support •TSBD • TSB DL • TSBD WS • TSBD WSG

Product description



Installed condition: TSBD WS, TSBD WSG

Annex A 3

TSBD



Marking

- Company logo – (KEW[®])
- Anchor type – (TSBD )
- (TSBDL )
- Diameter – (ø8)
- Length of anchor – (e.g. 160)

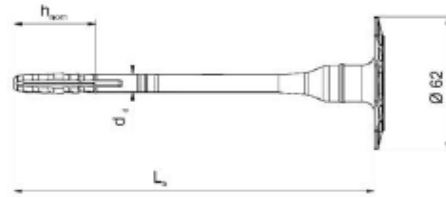

Special screw with special head

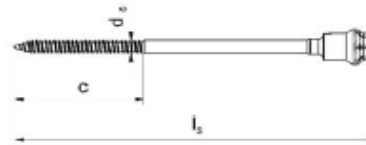

TSBDL

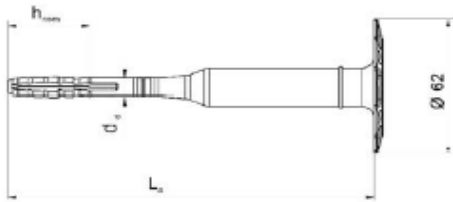

Special screw

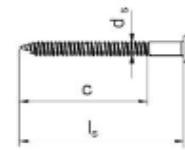

TSBD WS / WSG

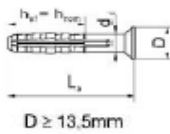

$D \geq 13,5\text{mm}$

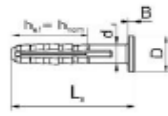

$B \geq 2,5\text{mm}$
 $D \geq 16\text{mm}$

Special screw



Installation tool



Anchor cap

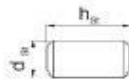

Insulation cover

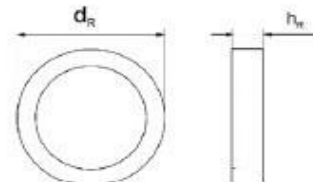

Insulation support • TSBD • TSBDL • TSBD WS • TSBD WSG

Product description

Marking of the anchor sleeve, dimensions, installation tool

Annex A 4

Table A1: Dimensions TSBD

Anchor type	Anchor sleeve				Special screw		
	L _a min [mm]	L _a max [mm]	d _d [mm]	h _{ef} [mm]	d _s [mm]	C [mm]	l _s [mm]
TSBD Use category (A-B-C)	100	440	8	30	5,5	52	L_a + 5mm
TSBD Use category (D-E)	100	440	8	30 50	5,5	52	L_a + 5mm
Determination of max. thickness of insulation: h_D = L_a - h_{nom} - t_{tol}							
e.g.: TSBD 8x160	L _a = 160		h _{ef} = 30		t _{tol} = 10		
	thickness of insulation material				h _{D,max.} = 120		
e.g.: TSBD 8x160	L _a = 160		h _{ef} = 50		t _{tol} = 10		
	thickness of insulation material				h _{D,max.} = 100		
Determination of max. thickness of insulation: h_D = L_a - h_{nom} - t_{tol} + Insulation cover							
e.g.: TSBD 8x160 With Insulation cover 20mm	L _a = 160		h _{ef} = 30		t _{tol} = 10		
	thickness of insulation material				h _{D,max.} = 140		
e.g.: TSBD 8x160 With Insulation cover 20mm	L _a = 160		h _{ef} = 50		t _{tol} = 10		
	thickness of insulation material				h _{D,max.} = 120		

Table A2: Dimensions TSB DL

Anchor type	Anchor sleeve				Special screw			
	L _a min [mm]	L _a max [mm]	d _d [mm]	h _{ef} [mm]	d _s [mm]	C [mm]	l _s min [mm]	l _s max [mm]
TSBDL Use category (A-B-C)	100	440	8	30	5,5	52	70	310
TSBDL Use category (D-E)	100	440	8	30 50	5,5	52	70	310
Determination of max. thickness of insulation: h_D = L_a - h_{nom} - t_{tol}								
e.g.: TSBDL 8x160	L _a = 160		h _{ef} = 30		t _{tol} = 10			
	thickness of insulation material				h _{D,max.} = 120			
e.g.: TSBDL 8x160	L _a = 160		h _{ef} = 50		t _{tol} = 10			
	thickness of insulation material				h _{D,max.} = 100			
Determination of max. thickness of insulation: h_D = L_a - h_{nom} - t_{tol} + Insulation cover								
e.g.: TSBDL 8x160 With Insulation cover 20mm	L _a = 160		h _{ef} = 30		t _{tol} = 10			
	thickness of insulation material				h _{D,max.} = 140			
e.g.: TSBDL 8x160 With Insulation cover 20mm	L _a = 160		h _{ef} = 50		t _{tol} = 10			
	thickness of insulation material				h _{D,max.} = 120			

Insulation support • TSBD • TSB DL • TSBD WS • TSBD WSG

Product description
Dimensions: TSBD, TSB DL

Annex A 5

Table A3: Dimensions TSBD WS / WSG

Anchor type	Anchor sleeve				Special screw		
	L _a min [mm]	L _a max [mm]	d _d [mm]	h _{ef} [mm]	d _s [mm]	c [mm]	l _s [mm]
TSBD WS / WSG Use category (A-B-C)	50	250	8	30	5,5	52	L_a + 5mm
TSBD WS / WSG Use category (D-E)	70	250	8	30 50	5,5	52	L_a + 5mm

Table A4: Dimensions Insulation cover and Anchor cap

Anchor type	Insulation cover		Anchor cap	
	d _R [mm]	h _R [mm]	d _{St} [mm]	h _{St} [mm]
TSBD	66	20	-	-
TSBDL	66	20	13	30

Table A5: Materials

Member	Material
Anchor sleeve	Polypropylen, colour: papyrus white
Special screw	Steel, galvanized A2L or A2K according to EN ISO 4042:2001-01 Stainless steel; mat.No. 1.4401 – 1.4571 according to EN ISO 3506-01:2010-04
Special head on Special screw	PA GF
Anchor cap	Polystyrene
Insulation cover	Polystyrene Mineral wool

Insulation support · TSBD · TSBDL · TSBD WS · TSBD WSG**Product description**

Dimensions: TSBD WS, TSBD WSG, anchor cap, insulation cover, materials

Annex A 6

Insulation discs

DSB 90

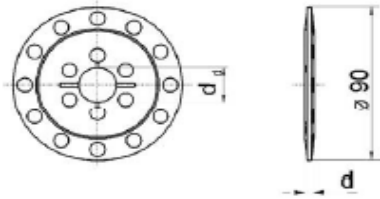

DSB 110

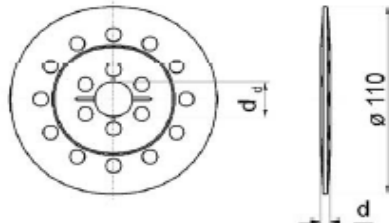

DSB 140

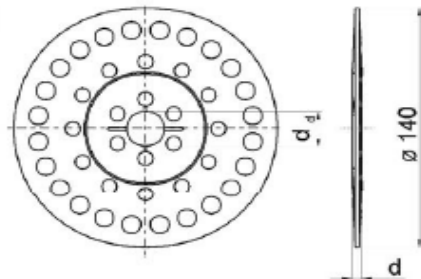

Table A6: Insulation discs, diameters and material

Insulation discs	$\varnothing D$ [mm]	$\varnothing d_d$ [mm]	d [mm]	Material
DSB 90	90	20	5	PA 6, PP
DSB 110	110	20	5	PA 6, PP
DSB 140	140	20	5	PA 6, PP

Insulation support ·TSBD ·TSBDL ·TSBD WS ·TSBD WSG

Product description

Additional plates in combination with TSBD, TSBDL

Annex A 7

Specifications of intended use

Anchorage subject to:

- The anchor may only be used for transmission of wind suction loads and shall not be used for the transmission of dead loads of the thermal insulation composite system.

Base materials:

- Normal weight concrete (use category A) according to Annex C 1
- Solid masonry (use category B), according to Annex C 1
- Hollow or perforated masonry (use category C), according to Annex C 1 and C 5
- Lightweight aggregate concrete (use category D), according to Annex C 1
- Autoclaved aerated concrete (use category E), according to Annex C 1
- For other base materials of the use categories A, B, C, D or E the characteristic resistance of the anchor may be determined by job site tests according to ETAG 014 Edition February 2011, Annex D.

Temperature Range:

- 0°C to +40°C (max. short term temperature +40°C and max. long term temperature +24°C)

Design:

- The anchorages are designed in accordance with the ETAG 014 Edition February 2011 under the responsibility of an engineer experienced in anchorages and masonry work.
- Verifiable calculation notes and drawings are prepared taking account of the loads to be anchored.
- Fasteners are only to be used for multiple fixings of thermal insulation composite systems.

Installation:

- Hole drilling by the drill modes according to Annex C 1
- Anchor installation carried out by appropriately qualified personnel and under the supervision of the person responsible for technical matters of the site.
- Installation temperature from 0°C to +40°C
- Exposure to UV due to solar radiation of the anchor not protected by rendering ≤ 6 weeks

Insulation support •TSBD • TSBDL • TSBD WS • TSBD WSG

Intended Use
Specifications

Annex B 1

Table B1: Installation parameters

Anchor type		TSBD, TSB DL		
		Use category		
		A-B-C	D-E	
Drill hole diameter	$d_0 =$ [mm]	8	8	
Cutting diameter of drill bit	$d_{cut} \leq$ [mm]	8,45	8,45	
Depth of drilled hole to deepest point	$h_i \geq$ [mm]	40	40	60
Effective anchorage depth	$h_{ed} =$ [mm]	30	30	50

Table B2: Minimum distances and dimensions

		TSBD, TSB DL
Minimum thickness of member	$h =$ [mm]	100
Minimum allowable spacing	$s_{min} =$ [mm]	100
Minimum allowable edge distance	$c_{min} =$ [mm]	100

Edge and spacing distances

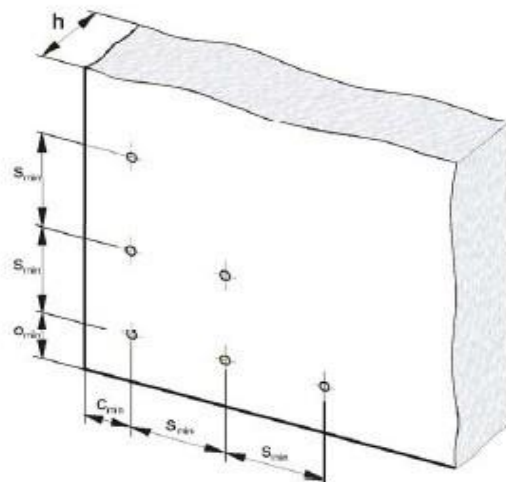

Insulation support •TSBD • TSB DL • TSB DL WS • TSB DL WSG

Intended Use
Installation parameters;
Edge distances and spacing

Annex B 2

Installation instructions TSBD surface-flush mounted

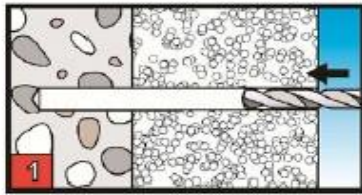

Create a hole considering the drill method according Annex C 1

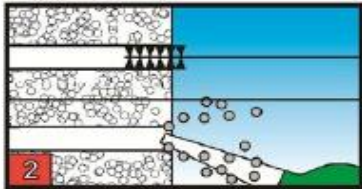

Holes to be cleaned of drilling dust

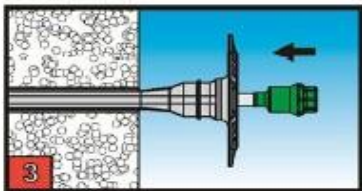

Insert the anchor into the hole until the plate rests on the insulation.

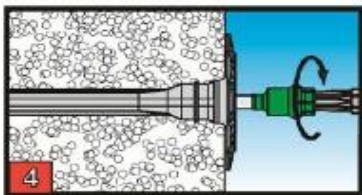

Set the screw with the matching bit

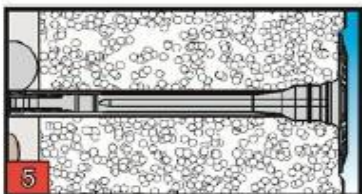

Surface-flush mounted

Insulation support •TSBD • TSBDL • TSBD WS • TSBD WSG

Intended Use
Installation instructions TSBD - surface-flush mounted

Annex B 3

Installation instructions TSBDL surface-flush mounted

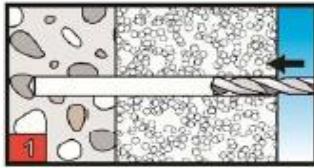

Create a hole considering the drill method according Annex C 1

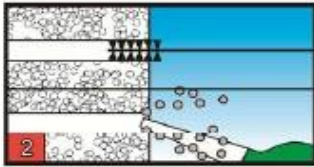

Holes to be cleaned of drilling dust

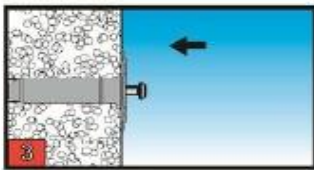

Insert the anchor into the hole until the plate rests on the insulation.

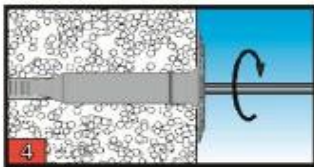

Set the screw with the matching bit

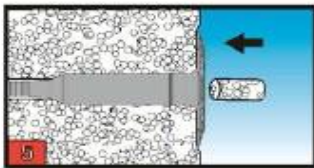

Put the anchor cap in to the anchor



Surface-flush mounted

Insulation support · TSBD · TSBDL · TSBD WS · TSBD WSG

Intended Use

Installation instructions TSBDL - surface-flush mounted

Annex B 4

Installation instructions TSBD countersunk



Create a hole considering the drill method according Annex C 1

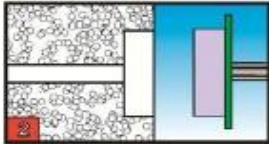

Countersink the insulation



Holes to be cleaned of drilling dust

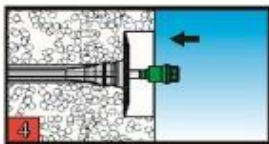

Insert the anchor into the hole until the plate rests on the insulation.

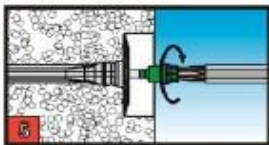

Set the screw with the matching bit

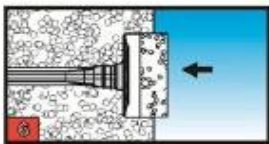

Put the Insulation cover into the insulation

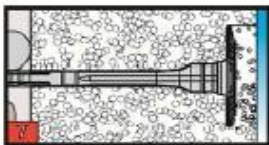

countersunk installation

Insulation support · TSBD · TSBDL · TSBD WS · TSBD WSG

Intended Use

Installation instructions TSBD – countersunk installation

Annex B 5

Installation instructions TSBDL countersunk

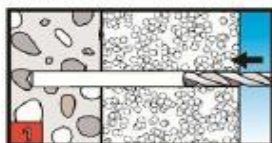

Create a hole considering the drill method according Annex C 1

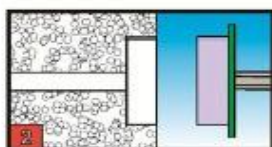

Countersink the insulation



Holes to be cleaned of drilling dust

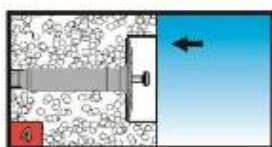

Insert the anchor into the hole until the plate rests on the insulation.

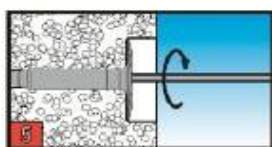

Set the screw with the matching bit

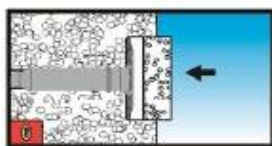

Put the Insulation cover into the insulation



countersunk installation

<p>Insulation support -TSBD - TSBDL - TSBD WS - TSBD WSG</p>	<p>Annex B 6</p>
<p>Intended Use Installation instructions TSBDL - countersunk installation</p>	

Table C1: Characteristic resistance N_{Rk} in [kN] to tension loads for a single anchor

Base material	Bulk density-class ρ [kg/dm ³]	Minimum compressive strength f_k [N/mm ²]	Remarks	Drill method	N_{Rk} [kN]
Concrete C12/15 EN 206-1:2000				Hammer drilling	1,5
Concrete C16/20 – C50/60 EN 206-1:2000					1,5
Sand-lime solid bricks, KS e.g. acc. to DIN V 106:2005-10 / EN 771-2:2011	≥ 1.8	12	Vertically perforation up to 15%		1,5
Clay bricks, Mz e.g. acc. to DIN 105-100:2012-01 / EN 771-1:2011	≥ 1.7	12	Vertically perforation up to 15%		1,5
Lightweight concrete solid blocks, Vbl 2 e.g. acc. to DIN V 18152-100:2005-10 / EN 771-3:2011	≥ 0.8	2	according to Annex C 5		0,75
Lightweight concrete solid blocks, Vbl 4 e.g. acc. to DIN V 18152-100:2005-10 / EN 771-3:2011	≥ 0.8	4	according to Annex C 5		1,2
Vertically perforated clay bricks, HLz e.g. acc. to DIN 105-100:2012-01 / EN 771-1:2011 with outer web thickness ≥ 12 mm	≥ 1.0	12	Vertically perforation more than 15% and less than 50%	Rotary drilling	0,9
Vertically perforated sand-lime bricks, KSL e.g. acc. to DIN V 106:2005-10 / EN 771-2:2011 with outer web thickness ≥ 20 mm	≥ 1.4	12	Vertically perforation up to 15%		1,5
Lightweight concrete hollow blocks, 4K Hbl e.g. acc. to DIN V 18151-100:2005-10 / EN 771-3:2011	≥ 0.9	2	according to Annex C 5		0,75
Lightweight concrete hollow blocks, 1K Hbl e.g. acc. to DIN V 18151-100:2005-10 / EN 771-3:2011	≥ 0.8	2	according to Annex C 5		0,9
Vertically perforated clay bricks, Hlz 250x380x235	≥ 1.0	6	according to Annex C 5		0,5
Lightweight aggregate concrete, LAC 4 e.g. acc. to EN 1520:2011 / EN 771-3:2011	≥ 1.0	4	$h_{ef} \geq 30$ mm $h_{ef} \geq 50$ mm		Hammer drilling
Lightweight aggregate concrete, LAC 6 e.g. acc. to EN 1520:2011 / EN 771-3:2011	≥ 1.0	6	$h_{ef} \geq 30$ mm $h_{ef} \geq 50$ mm	0,5 1,2	
autoclaved aerated concrete PP4-0,5 e.g. acc. to DIN V 4165-100:2005-10 / EN 771-4:2011	≥ 0.5	4	$h_{ef} \geq 30$ mm $h_{ef} \geq 50$ mm	Rotary drilling	0,30 0,75

Insulation support •TSBD • TSB DL • TSB D WS • TSB D WSG

Performances

Characteristic resistance of the anchor

Annex C 1

Table C2: Point thermal transmittance according to EOTA Technical Report TR 025:2007-06

Anchor type	thickness of insulation h_D [mm]	Point thermal transmittance χ [W/K]
TSBD specific screw of galvanized steel	$\leq 150\text{mm}$	0,003
TSBD specific screw of galvanized steel	$> 150\text{mm}$	0,002
TSBD specific screw of stainless steel	$\leq 150\text{mm}$	0,002
TSBD specific screw of stainless steel	$> 150\text{mm}$	0,001

Anchor type	thickness of insulation h_D [mm]	Point thermal transmittance χ [W/K]
TSBD + Insulation cover specific screw of galvanized steel	$\leq 150\text{mm}$	0,002
TSBD + Insulation cover specific screw of galvanized steel	$> 150\text{mm}$	0,002
TSBD + Insulation cover specific screw of stainless steel	$\leq 150\text{mm}$	0,001
TSBD + Insulation cover specific screw of stainless steel	$> 150\text{mm}$	0,001

Insulation support • TSBD • TSB DL • TSBD WS • TSBD WSG

Performances
Point thermal transmittance

Annex C 2

Continuation of Table C2: Point thermal transmittance according to EOTA Technical Report TR 025:2007-06

Anchor type	thickness of insulation h_D [mm]	Point thermal transmittance χ [W/K]
TSBDL specific screw of galvanized steel	≤80mm	0,002
TSBDL specific screw of galvanized steel	>80mm	0,001
TSBDL specific screw of stainless steel	≤240mm	0,001
TSBDL specific screw of stainless steel	>240mm	0,000

Anchor type	thickness of insulation h_D [mm]	Point thermal transmittance χ [W/K]
TSBDL + Insulation cover specific screw of galvanized steel	≤150mm	0,001
TSBDL + Insulation cover specific screw of galvanized steel	>150mm	0,001
TSBDL + Insulation cover specific screw of stainless steel	≤100mm	0,001
TSBDL + Insulation cover specific screw of stainless steel	>100mm	0,000

Insulation support •TSBD • TSBDL • TSBD WS • TSBD WSG

Performances
Point thermal transmittance

Annex C 3

Table C3: Plate stiffness according to EOTA Technical Report TR 026:2007-06

Anchor type	Diameter of anchor plate [mm]	Load resistance of anchor plate [kN]	Plate stiffness [kN/mm]
TSBD	60	2,22	1,6
TSBDL	60	2,22	1,6

Table C4: Displacements

Base material	Bulk-density-class ρ [kg/dm ³]	Minimum compressive strength f_k [N/mm ²]	Tension load	Displacements
			N [kN]	$\delta_m(N)$ [mm]
Concrete C12/15-C50/60 EN 206-1:2000			0,50	0,2
Sand-lime solid bricks, KS DIN V 106:2005-10 / EN 771-2:2011	≥1,8	12	0,50	0,3
Mauerziegel, Mz DIN 105-100:2012-01 / EN 771-1:2011	≥1,7	12	0,50	0,3
Lightweight concrete solid blocks, Vbl 2 DIN V 18152-100:2005-10 / EN 771-3:2011	≥0,8	2	0,25	0,3
Lightweight concrete solid blocks, Vbl 4 DIN V 18152-100:2005-10 / EN 771-3:2011	≥0,8	4	0,40	0,4
Vertically perforated clay bricks, HLz DIN 105-100:2012-01 / EN 771-1:2011	≥1,0	12	0,30	0,1
Vertically perforated sand-lime bricks, KSL DIN V 106:2005-10 / EN 771-2:2011	≥1,4	12	0,50	0,3
Lightweight concrete hollow blocks, 4K Hbl DIN V 18151-100:2005-10 / EN 771-3:2011	≥0,9	2	0,25	0,1
Lightweight concrete hollow blocks, 1K Hbl DIN V 18151-100:2005-10 / EN 771-3:2011	≥0,8	2	0,30	0,2
Vertically perforated clay bricks, Hlz 250x380x235	≥1,0	6	0,15	0,1
Lightweight aggregate concrete, LAC 4 EN 1520:2011 / EN 771-3:2011	≥1,0	4	$h_{ef} > 30$ mm: 0,15	0,1
			$h_{ef} \geq 50$ mm: 0,30	0,2
Lightweight aggregate concrete, LAC 6 EN 1520:2011 / EN 771-3:2011	≥1,0	6	$h_{ef} > 30$ mm: 0,15	0,1
			$h_{ef} \geq 50$ mm: 0,40	0,2
autoclaved aerated concrete DIN V 4165-100:2005-10 / EN 771-4:2011	≥0,5	4	$h_{ef} > 30$ mm: 0,10	0,15
			$h_{ef} \geq 50$ mm: 0,25	0,01

Insulation support •TSBD •TSBDL •TSBD WS •TSBD WSG
Performances
 Plate stiffness
 Displacements
Annex C 4

Table C5: Geometry of Hbl acc. DIN V 18151-100:2005-10 / EN 771-3:2011

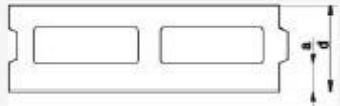
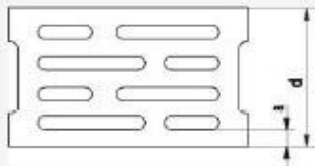
Geometry	Thickness of brick	Outer web in longitudinal direction
	d [mm]	a [mm]
	175	50
	240 300 365	30

The anchor shall be placed in the brick in such way, that the spreading part of the expansion sleeve is located in the outer web.

Table C6: Geometry of Vbl according to DIN V 18152-100:2005-10 / EN 771-3:2011

Geometry	Thickness of brick	Outer web in longitudinal direction
	d [mm]	a [mm]
	248 300 370	≥ 43

Table C7: Geometry of vertically perforated clay bricks Hlz 250x380x235

Geometry	Thickness of brick	Outer web in longitudinal direction
	d [mm]	a [mm]
	250	≥ 16

Insulation support ·TSBD · TSB DL · TSBD WS · TSBD WSG

Performances

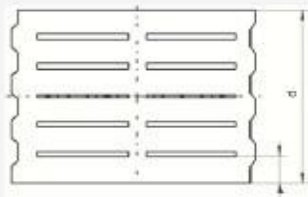
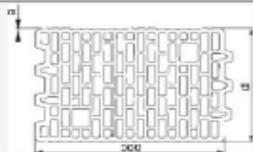
Geometry of lightweight concrete hollow blocks and solid blocks, vertically perforated clay brick 250x380x235

Annex C 5