

Approval body for construction products  
and types of construction

Bautechnisches Prüfamt

An institution established by the Federal and  
Laender Governments



## European Technical Assessment

ETA-08/0314  
of 24 August 2020

English translation prepared by DIBt - Original version in German language

### General Part

Technical Assessment Body issuing the  
European Technical Assessment:

Deutsches Institut für Bautechnik

Trade name of the construction product

Insulation support TSBD, TSBD X, TSB DL, TSBD WS  
and TSBD WSG

Product family  
to which the construction product belongs

Screwed-in plastic anchor for fixing of external thermal  
insulation composite systems with rendering in concrete  
and masonry

Manufacturer

KEW  
Kunststoffzeugnisse GmbH Wilthen  
Dresdener Straße 19  
02681 Wilthen  
DEUTSCHLAND

Manufacturing plant

KEW  
Kunststoffzeugnisse GmbH Wilthen  
Dresdener Straße 19  
02681 Wilthen  
DEUTSCHLAND

This European Technical Assessment  
contains

26 pages including 3 annexes which form an integral part  
of this assessment

This European Technical Assessment is  
issued in accordance with Regulation (EU)  
No 305/2011, on the basis of

EAD 330196-01-0604, Edition 10/2017

This version replaces

ETA-08/0314 issued on 15 April 2015

The European Technical Assessment is issued by the Technical Assessment Body in its official language. Translations of this European Technical Assessment in other languages shall fully correspond to the original issued document and shall be identified as such.

Communication of this European Technical Assessment, including transmission by electronic means, shall be in full. However, partial reproduction may only be made with the written consent of the issuing Technical Assessment Body. Any partial reproduction shall be identified as such.

This European Technical Assessment may be withdrawn by the issuing Technical Assessment Body, in particular pursuant to information by the Commission in accordance with Article 25(3) of Regulation (EU) No 305/2011.

**Specific Part**

**1 Technical description of the product**

The insulation support metal screw TSBD, TSBD X, TSBDL, TSBD WS und TSBD WSG is a screwed-in anchor which consists of a plastic part made of polypropylene (virgin material) and an accompanying specific screw of galvanised steel or stainless steel and an anchor cap made of polystyrene (for mounting the anchor on the surface of the insulating material) or an insulation cover made of polystyrene or mineral wool (for deep mounting of the anchor in the insulating material).

The anchor types TSBD, TSBD X und TSBDL may in addition be combined with the insulation discs DSB 90, DSB 110 and DSB 140.

The head of the screw for anchor type TSBD has an additional plastic coating.

The product description is given in Annex A.

**2 Specification of the intended use in accordance with the applicable European Assessment Document**

The performances given in Section 3 are only valid if the anchor is used in compliance with the specifications and conditions given in Annex B.

The verification and assessment methods on which this European Technical Assessment is based lead to the assumption of a working life of the anchor of at least 25 years. The indications given on the working life cannot be interpreted as a guarantee given by the producer, but are to be regarded only as a means for choosing the right products in relation to the expected economically reasonable working life of the works.

**3 Performance of the product and references to the methods used for its assessment**

**3.1 Safety and accessibility in use (BWR 4)**

Essential characteristic	Performance
Characteristic load bearing capacity	
- Characteristic resistance under tension load	See Annex C 1
- Minimum edge distance and spacing	See Annex B 2
Displacements	See Annex C 2
Plate stiffness	See Annex C 5

**3.2 Energy economy and heat retention (BWR 6)**

Essential characteristic	Performance
Point thermal transmittance	See Annex C 3 - C 5

**4 Assessment and verification of constancy of performance (AVCP) system applied, with reference to its legal base**

In accordance with EAD No. 330196-01-0604, the applicable European legal act is: [97/463/EC].

The system to be applied is: 2+

English translation prepared by DIBt

**5 Technical details necessary for the implementation of the AVCP system, as provided for in the applicable EAD**

Technical details necessary for the implementation of the AVCP system are laid down in the control plan deposited with Deutsches Institut für Bautechnik.

Issued in Berlin on 24 August 2020 by Deutsches Institut für Bautechnik

BD Dipl.-Ing. Andreas Kummerow  
Head of Department

*beglaubigt:*  
Aksünger

**TSBD**

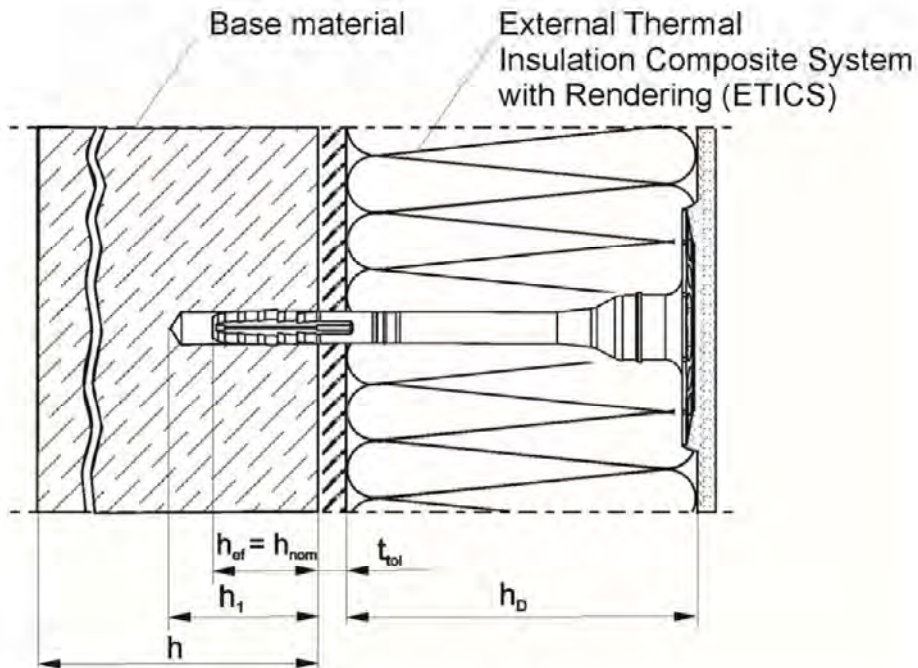

**TSBD X**

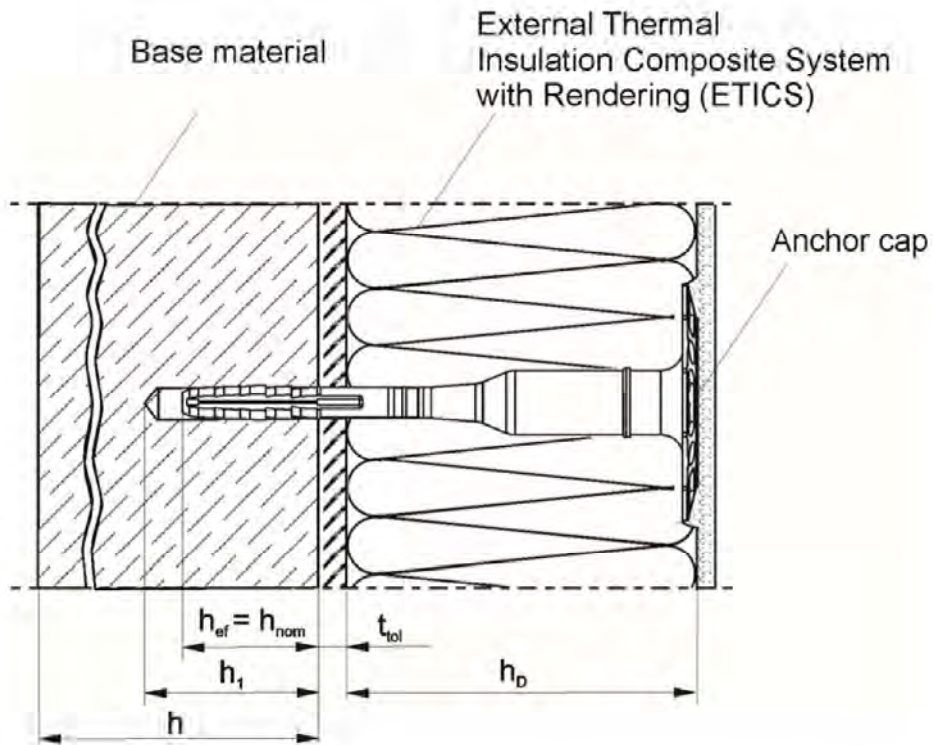

Insulation support • TSBD • TSBD X • TSBDL • TSBD WS • TSBD WSG

**Product description**  
Intended use: TSBD, TSBD X

Annex A 1

TSBDL

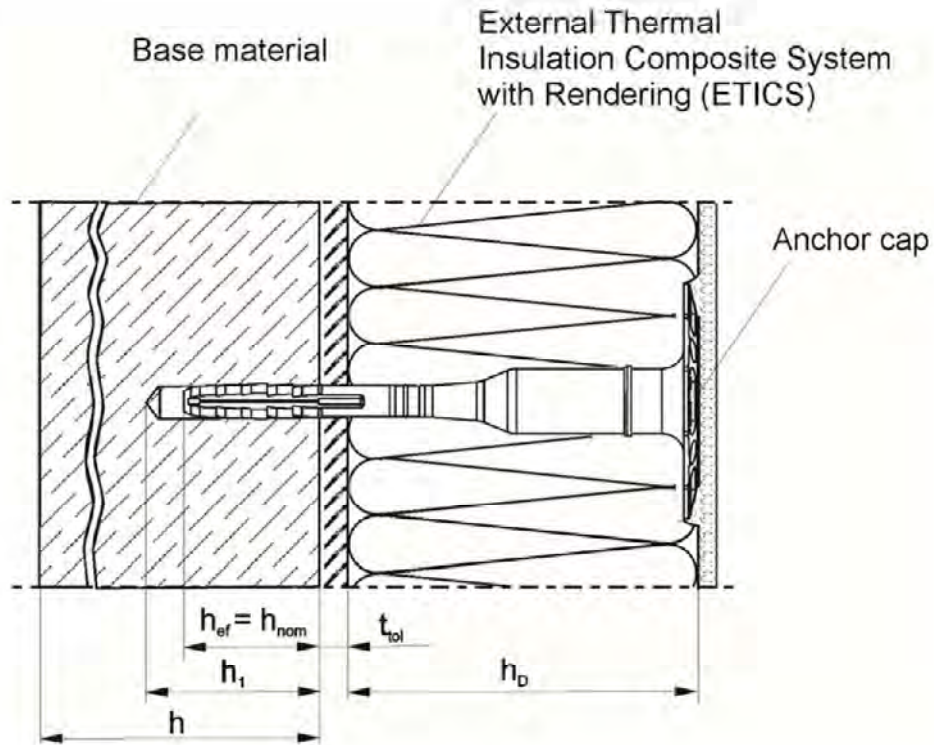

Insulation support • TSBD • TSBD X • TSBDL • TSBD WS • TSBD WSG

Product description  
Intended use: TSBDL

Annex A 2

**TSBD +  
Insulation cover**

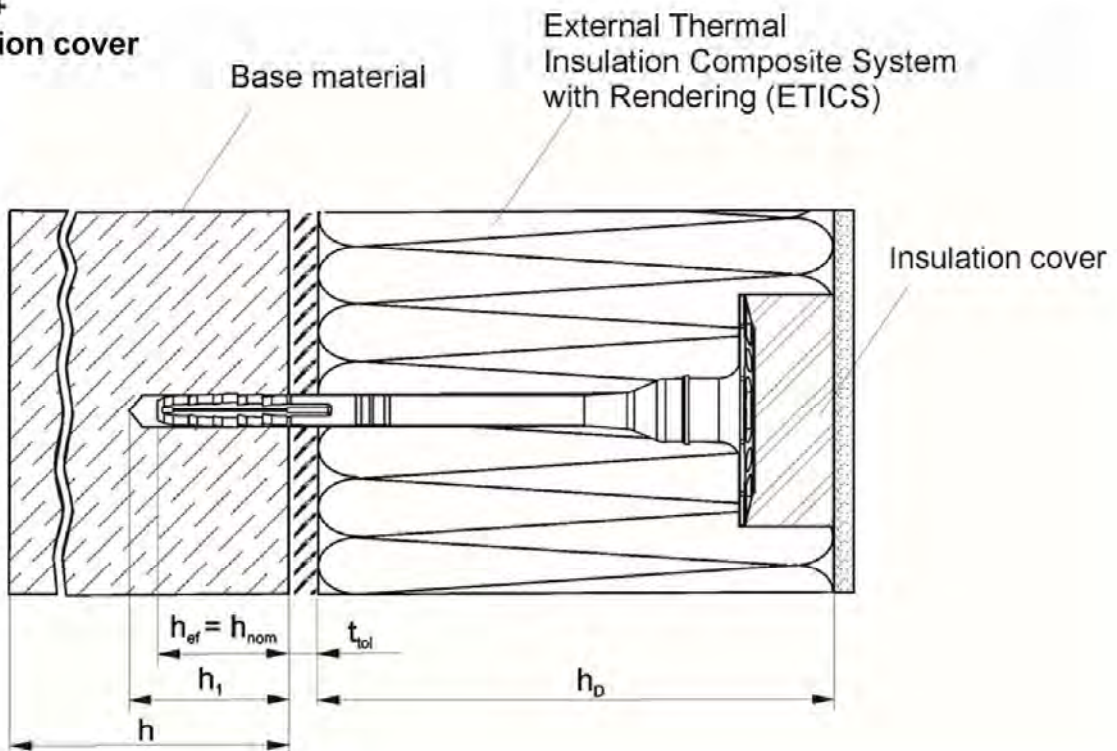

**TSBD X +  
Insulation cover**

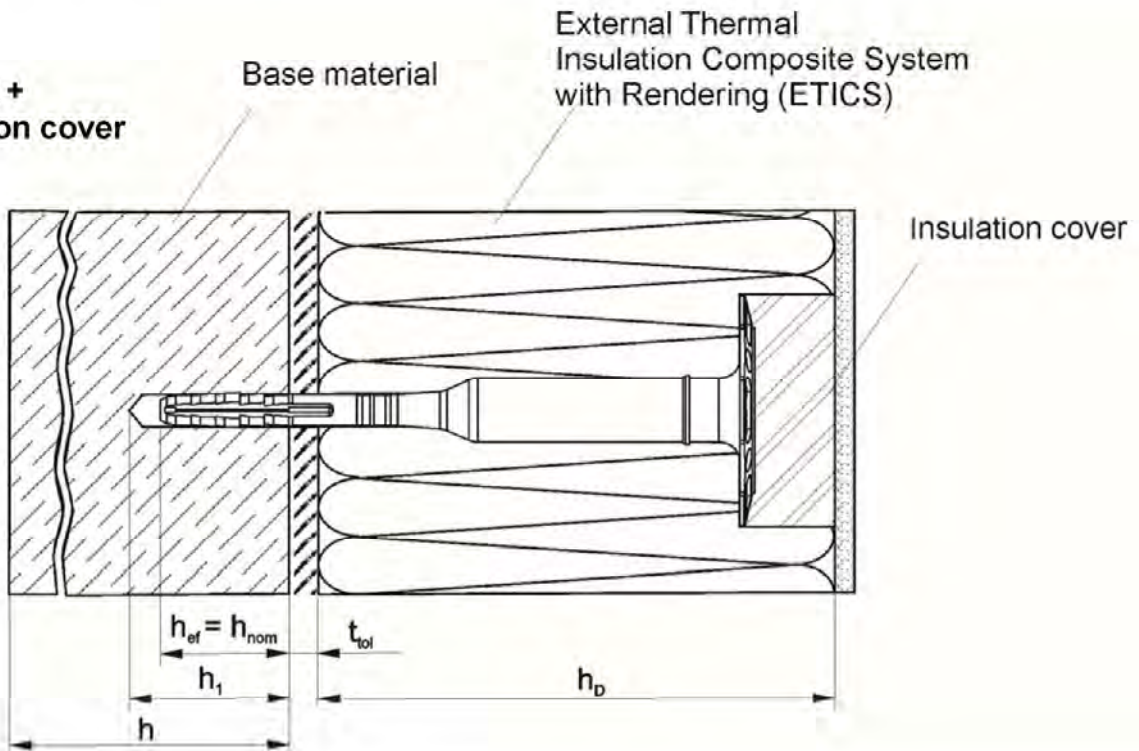

Insulation support • TSBD • TSBD X • TSBDL • TSBD WS • TSBD WSG

**Product description**

Intended use + Insulation cover: TSBD, TSBD X

Annex A 3

**TSBDL +  
Insulation cover**

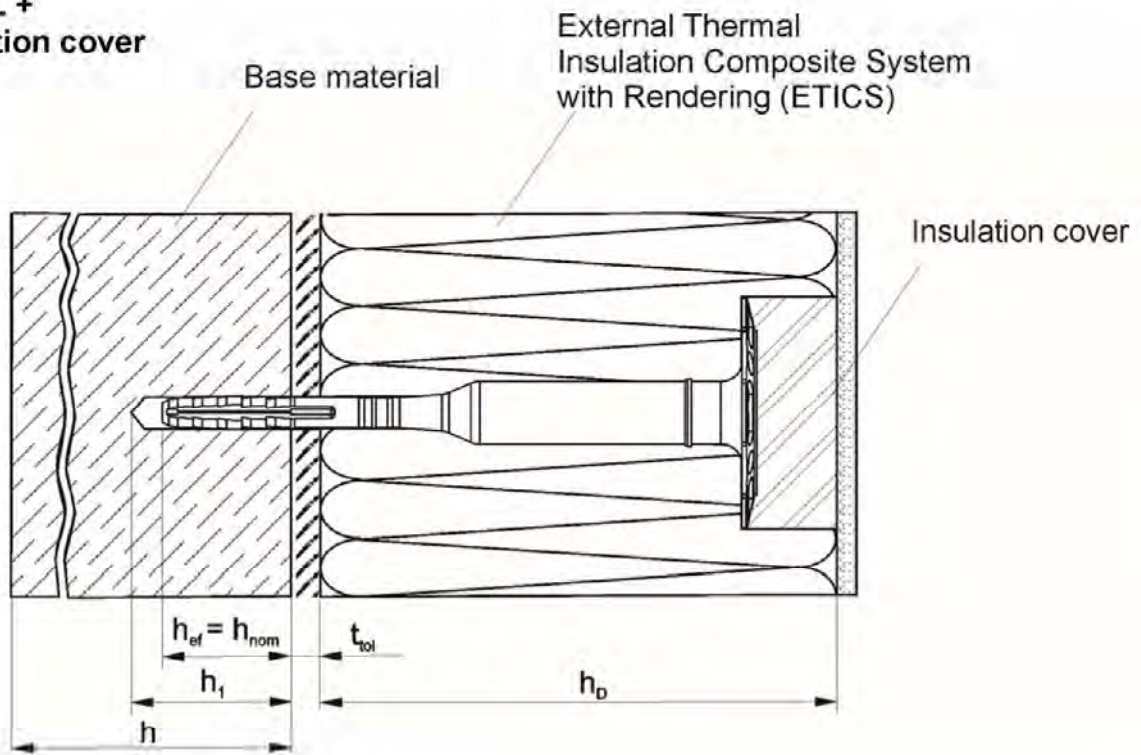

Electronic copy of the ETA by DIBt: ETA-08/0314

**Insulation support • TSBD • TSBD X • TSBDL • TSBD WS • TSBD WSG**

**Product description**

Intended use + Insulation cover: TSBDL

Annex A 4



**TSBD WS**

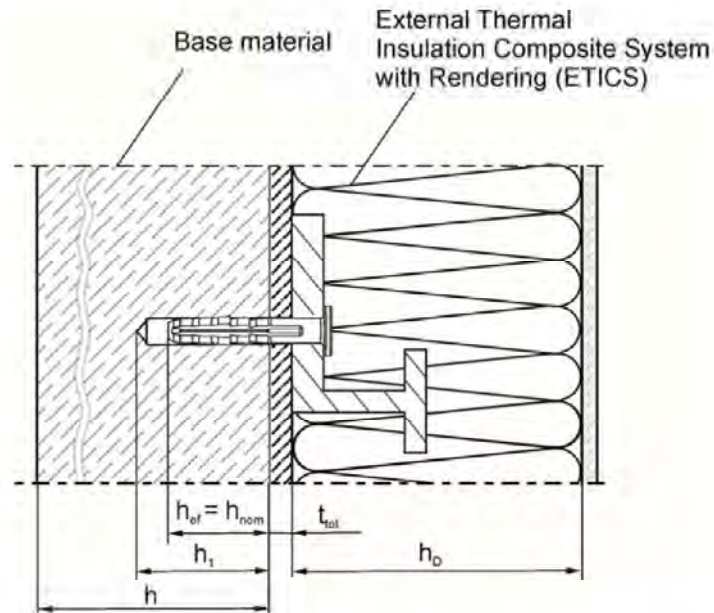

**TSBD WSG**

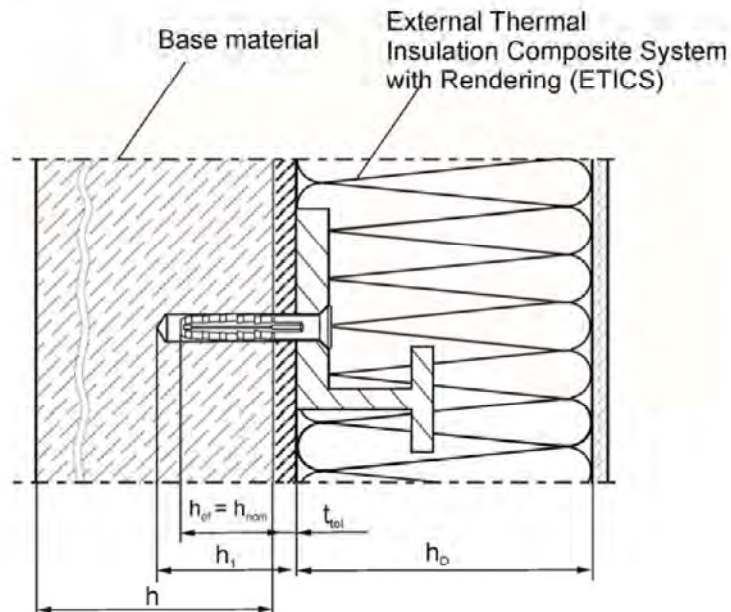

**Legend**

- $h_{ef}$  = effective anchorage depth
- $h_1$  = depth of drilled hole to deepest point
- $h$  = thickness of member (wall)
- $h_D$  = thickness of insulation material
- $t_{tol}$  = thickness of equalizing layer or non-load bearing coating

**Insulation support • TSBD • TSBD X • TSBDL • TSBD WS • TSBD WSG**

**Product description**

Intended use: TSBD WS, TSBD WSG

Annex A 5

English translation prepared by DIBt

### TSBD



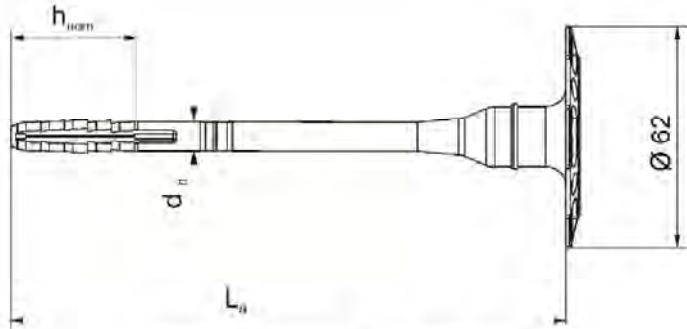

Ø 60



#### Marking

Company logo – (KEW®)

Anchor type – (TSBD )

– (TSBD X )

– (TSBDL )

Diameter – (Ø8)

Length of anchor – (e.g. 160)

Special screw with special head

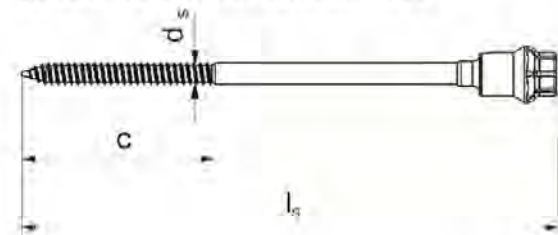

### TSBD X

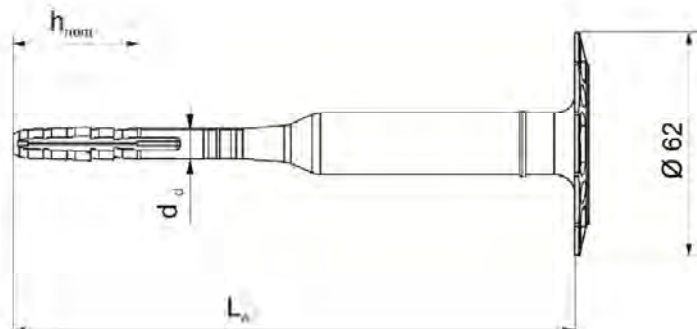

Special screw

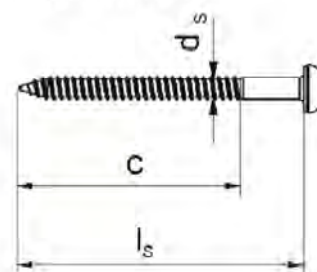

### TSBDL

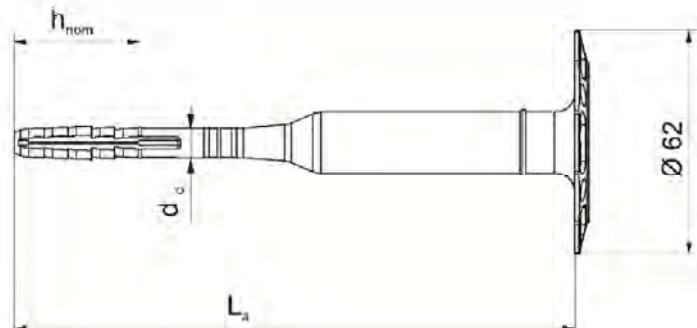

Special screw

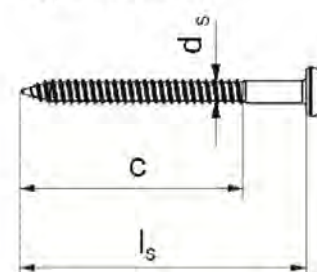

Insulation support • TSBD • TSBD X • TSBDL • TSBD WS • TSBD WSG

#### Product description

Marking of the anchor sleeve, dimensions: TSBD, TSBD X, TSBD L

Annex A 6

**TSBD WS / WSG**

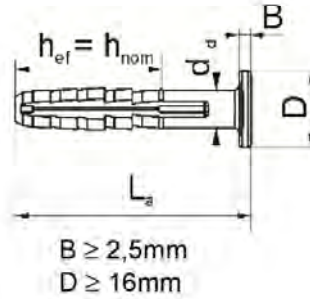
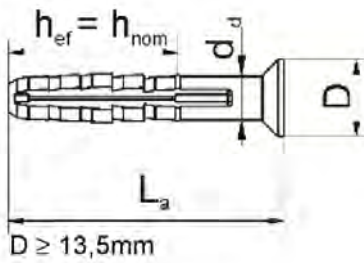

Special screw

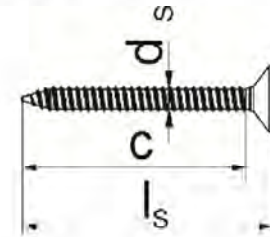

Installation tool



Anchor cap I  
to close the anchor

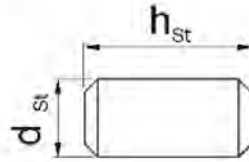

Anchor cap II  
to close the anchor

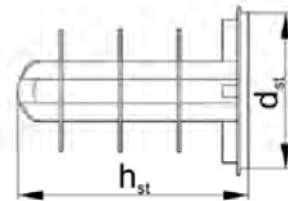

Insulation cover

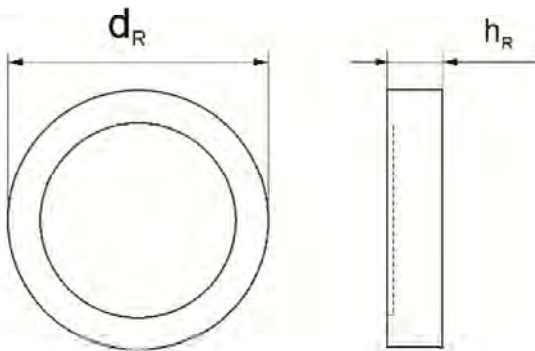

Insulation support • TSBD • TSBD X • TSBDL • TSBD WS • TSBD WSG

**Product description**

Marking of the anchor sleeve, installation tool,  
dimensions: TSBD WS / WSG, Installation tool, Anchor cap

Annex A 7

**Table A1: Dimensions TSBD**

Anchor type	Anchor sleeve				Special screw			
	L <sub>a</sub> min [mm]	L <sub>a</sub> max [mm]	d <sub>d</sub> [mm]	h <sub>ef</sub> [mm]	d <sub>s</sub> [mm]	c [mm]	l <sub>s</sub> [mm]	
<b>KEW® - TSBD</b> base material group A-B-C	100	440	8	30	5,5	52	L <sub>a</sub> + 5mm	
<b>KEW® - TSBD</b> base material group D-E	100	440	8	30	50	5,5	52	L <sub>a</sub> + 5mm
Determination of max. thickness of insulation: $h_D = L_a - h_{nom} - t_{tol}$								
e.g.: TSBD 8x160	L <sub>a</sub> = 160		h <sub>ef</sub> = 30		t <sub>tol</sub> = 10			thickness of insulation material $h_{D max.} = 120$
e.g.: TSBD 8x160	L <sub>a</sub> = 160		h <sub>ef</sub> = 50		t <sub>tol</sub> = 10			thickness of insulation material $h_{D max.} = 100$
Determination of max. thickness of insulation: $h_D = L_a - h_{nom} - t_{tol} + \text{Insulation cover}$								
e.g.: TSBD 8x160 With Insulation cover 20mm	L <sub>a</sub> = 160		h <sub>ef</sub> = 30		t <sub>tol</sub> = 10			thickness of insulation material $h_{D max.} = 140$
e.g.: TSBD 8x160 With Insulation cover 20mm	L <sub>a</sub> = 160		h <sub>ef</sub> = 50		t <sub>tol</sub> = 10			thickness of insulation material $h_{D max.} = 120$

**Table A2: Dimensions TSBD X**

Anchor type	Anchor sleeve				Special screw			
	L <sub>a</sub> min [mm]	L <sub>a</sub> max [mm]	d <sub>d</sub> [mm]	h <sub>ef</sub> [mm]	d <sub>s</sub> [mm]	c [mm]	l <sub>s</sub> [mm]	
<b>KEW® - TSBD X</b> base material group A-B-C	100	440	8	30	5,5	52	78	
<b>KEW® - TSBD X</b> base material group D-E	100	440	8	30	50	5,5	52	78
Determination of max. thickness of insulation: $h_D = L_a - h_{nom} - t_{tol}$								
e.g.: TSBD X 8x160	L <sub>a</sub> = 160		h <sub>ef</sub> = 30		t <sub>tol</sub> = 10			thickness of insulation material $h_{D max.} = 120$
e.g.: TSBD X 8x160	L <sub>a</sub> = 160		h <sub>ef</sub> = 50		t <sub>tol</sub> = 10			thickness of insulation material $h_{D max.} = 100$
Determination of max. thickness of insulation: $h_D = L_a - h_{nom} - t_{tol} + \text{Insulation cover}$								
e.g.: TSBD X 8x160 With Insulation cover 20mm	L <sub>a</sub> = 160		h <sub>ef</sub> = 30		t <sub>tol</sub> = 10			thickness of insulation material $h_{D max.} = 140$
e.g.: TSBD X 8x160 With Insulation cover 20mm	L <sub>a</sub> = 160		h <sub>ef</sub> = 50		t <sub>tol</sub> = 10			thickness of insulation material $h_{D max.} = 120$

Insulation support • TSBD • TSBD X • TSBDL • TSBD WS • TSBD WSG

**Product description**  
Dimensions: TSBD, TSBD X

Annex A 8

**Table A3: Dimensions TSBDL**

Anchor type	Anchor sleeve				Special screw			
	L <sub>a</sub> min [mm]	L <sub>a</sub> max [mm]	d <sub>d</sub> [mm]	h <sub>ef</sub> [mm]	d <sub>s</sub> [mm]	c [mm]	l <sub>s</sub> min [mm]	l <sub>s</sub> max [mm]
<b>KEW® - TSBDL</b> base material group A-B-C	<b>100</b>	<b>440</b>	<b>8</b>	<b>30</b>	<b>5,5</b>	<b>52</b>	<b>70</b>	<b>310</b>
<b>KEW® - TSBDL</b> base material group D-E	<b>100</b>	<b>440</b>	<b>8</b>	<b>30</b>	<b>50</b>	<b>5,5</b>	<b>70</b>	<b>310</b>
Determination of max. thickness of insulation: $h_D = L_a - h_{nom} - t_{tol}$								
e.g.: TSBDL 8x160	<b>L<sub>a</sub> = 160</b>		<b>h<sub>ef</sub> = 30</b>		<b>t<sub>tol</sub> = 10</b>			
thickness of insulation material <b>h<sub>D max.</sub> = 120</b>								
e.g.: TSBDL 8x160	<b>L<sub>a</sub> = 160</b>		<b>h<sub>ef</sub> = 50</b>		<b>t<sub>tol</sub> = 10</b>			
thickness of insulation material <b>h<sub>D max.</sub> = 100</b>								
Determination of max. thickness of insulation: $h_D = L_a - h_{nom} - t_{tol} + \text{Insulation cover}$								
e.g.: TSBDL 8x160 With Insulation cover 20mm	<b>L<sub>a</sub> = 160</b>		<b>h<sub>ef</sub> = 30</b>		<b>t<sub>tol</sub> = 10</b>			
thickness of insulation material <b>h<sub>D max.</sub> = 140</b>								
e.g.: TSBDL 8x160 With Insulation cover 20mm	<b>L<sub>a</sub> = 160</b>		<b>h<sub>ef</sub> = 50</b>		<b>t<sub>tol</sub> = 10</b>			
thickness of insulation material <b>h<sub>D max.</sub> = 120</b>								

**Table A4: Dimensions TSBD WS / WSG**

Anchor type	Anchor sleeve				Special screw		
	L <sub>a</sub> min [mm]	L <sub>a</sub> max [mm]	d <sub>d</sub> [mm]	h <sub>ef</sub> [mm]	d <sub>s</sub> [mm]	c [mm]	l <sub>s</sub> [mm]
<b>KEW® - TSBD WS / WSG</b> base material group A-B-C	<b>50</b>	<b>250</b>	<b>8</b>	<b>30</b>	<b>5,5</b>	<b>52</b>	<b>L<sub>a</sub> + 5mm</b>
<b>KEW® - TSBD WS / WSG</b> base material group D-E	<b>70</b>	<b>250</b>	<b>8</b>	<b>30</b>	<b>50</b>	<b>5,5</b>	<b>52</b>
<b>L<sub>a</sub> + 5mm</b>							

Insulation support • TSBD • TSBD X • TSBDL • TSBD WS • TSBD WSG

**Product description**  
Dimensions: TSBDL, TSBD WS, TSBD WSG

Annex A 9

**Table A5: Dimensions Insulation cover and Anchor cap**

Anchor type	Insulation cover		Anchor cap I		Anchor cap II	
	d <sub>R</sub> [mm]	h <sub>R</sub> [mm]	d <sub>St</sub> [mm]	h <sub>St</sub> [mm]	d <sub>St</sub> [mm]	h <sub>St</sub> [mm]
KEW® - TSBD	66	20	-	-	-	-
KEW® - TSBD X	66	20	13	30	15	20
KEW® - TSBDL	66	20	13	30	15	20

**Table A6: Materials**

Member	Materials
Anchor sleeve	Polypropylen(virgin material), colour: papyrus white or nature
Special screw	Steel, galvanized A2G or A2F according to EN ISO 4042:2018
	Stainless steel according to EN 10088-3:2014; mat. No. 1.4401, 1.4571
Special head on Special screw	PA GF
Anchor cap	Polystyrene, Polypropylene, Polyethylene, Mineral wool
Insulation cover	Polystyrene, Mineral wool, Polyurethane

**Insulation support •TSBD • TSBD X • TSBDL • TSBD WS • TSBD WSG**

**Product description**  
Dimensions: Installation tool, Anchor cap  
Materials

Annex A 10

### Insulation discs

DSB 90

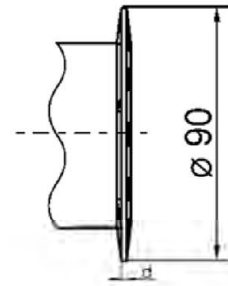
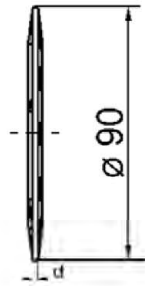
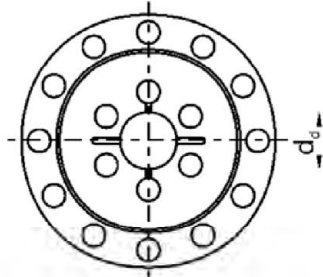

DSB 110

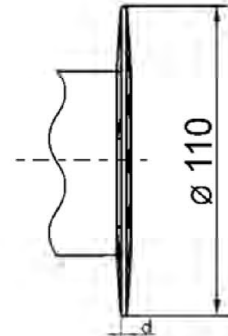
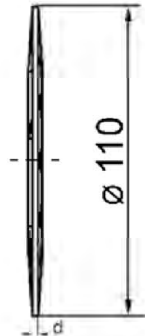
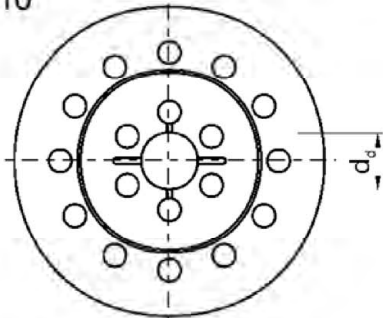

DSB 140

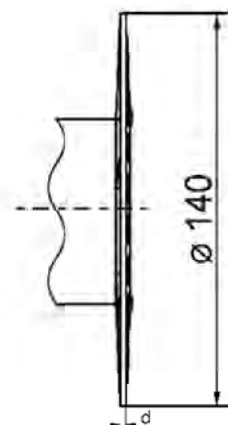
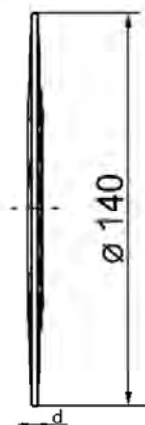
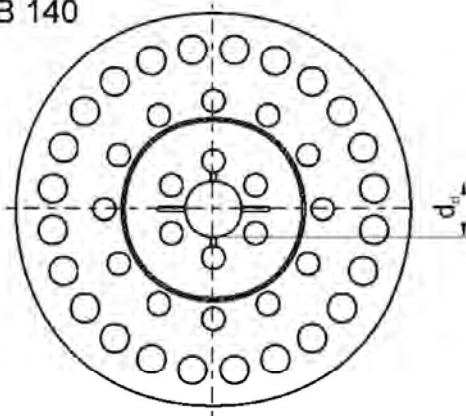

DSB I

DSB II

**Table A7: Insulation discs, diameters and material**

Insulation discs	Ø D [mm]	Ø d <sub>d</sub> [mm]	d [mm]	Material
DSB I / II 90	90	20	5	PA 6, PP
DSB I / II 110	110	20	5	PA 6, PP
DSB I / II 140	140	20	5	PA 6, PP

Insulation support •TSBD • TSBD X • TSB DL • TSBD WS • TSBD WSG

**Product description**

Additional plates in combination with KEW®- TSBD, TSBD X , TSB DL

Annex A 11

## Specifications of intended use

### Anchorage subject to:

- The anchor may only be used for transmission of wind suction loads and shall not be used for the transmission of dead loads of the thermal insulation composite system.

### Base materials:

- Normal weight concrete (base material group A) according to Annex C 1.
- Solid masonry (base material group B), according to Annex C 1.
- Hollow or perforated masonry (base material group C), according to Annex C 1.
- Lightweight aggregate concrete (base material group D), according to Annex C 1.
- Autoclaved aerated concrete (base material group E), according to Annex C 1.
- For other base materials of the use categories A, B, C, D or E the characteristic resistance of the anchor may be determined by job site tests according to EOTA Technical Report TR 051 edition December 2016.

### Temperature Range:

- 0°C to +40°C (max. short term temperature +40°C and max. long term temperature +24°C)

### Design:

- The anchorages are designed under the responsibility of an engineer experienced in anchorages and masonry work with the partial safety factors  $\gamma_M = 2,0$  and  $\gamma_F = 1,5$ , if there are no other national regulations.
- Verifiable calculation notes and drawings are prepared taking account of the loads to be anchored. The position of the anchor is indicated on the design drawings.
- Fasteners are only to be used for multiple fixings for non-structural application.

### Installation:

- Hole drilling by the drill modes according to Annex C 1.
- Anchor installation carried out by appropriately qualified personnel and under the supervision of the person responsible for technical matters of the site.
- Installation temperature from 0°C to +40°C
- Exposure to UV due to solar radiation of the anchor not protected by rendering  $\leq 6$  weeks

Insulation support •TSBD • TSBD X • TSB DL • TSBD WS • TSBD WSG

Intended Use  
Specifications

Annex B 1



**Table B1: Installation parameters**

Anchor type		KEW®- TSBD, TSBD X, TSBDL		
		base material group		
		A-B-C	D-E	
Drill hole diameter	$d_o =$ [mm]	8	8	
Cutting diameter of drill bit	$d_{cut} \leq$ [mm]	8,45	8,45	
Depth of drilled hole to deepest point	$h_1 \geq$ [mm]	40	40	60
Effective anchorage depth	$h_{ef} =$ [mm]	30	30	50

**Table B2: Minimum distances and dimension**

		KEW®- TSBD, TSBD X, TSBDL
Minimum thickness of member	$h =$ [mm]	100
Minimum spacing	$s_{min} =$ [mm]	100
Minimum edge distance	$c_{min} =$ [mm]	100

Edge and spacing distances

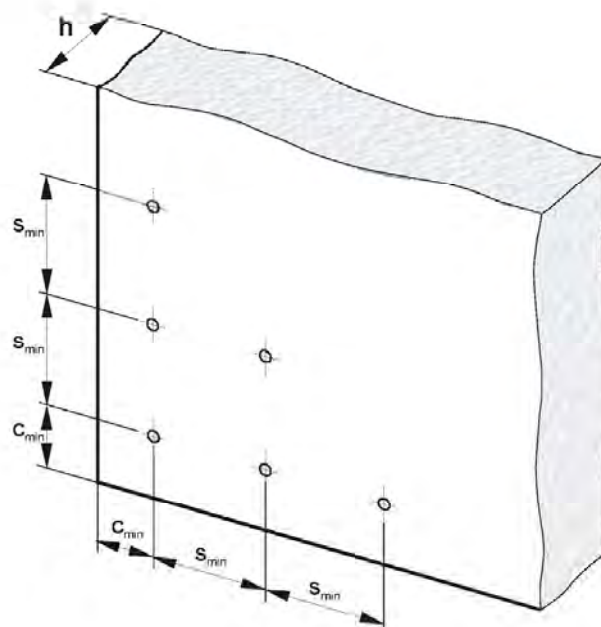

Insulation support • TSBD • TSBD X • TSBDL • TSBD WS • TSBD WSG

**Intended Use**  
Installation parameters,  
Edge distances and spacing

Annex B 2

### Installation instructions TSBD surface-flush mounted



Create a hole about observation of the drill method according Annex C 1

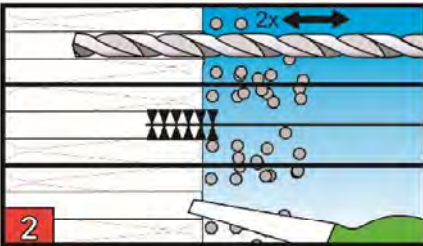

Holes to be cleaned of drilling dust.

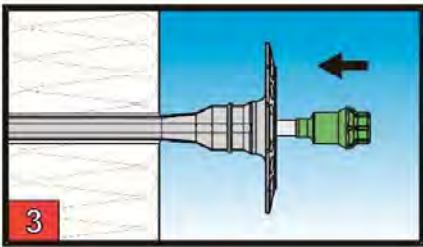

Insert the anchor into the hole until the plate rests on the insulation.

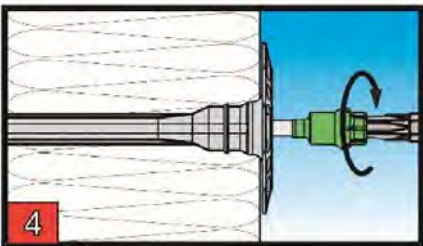

Set the screw with the matching bit

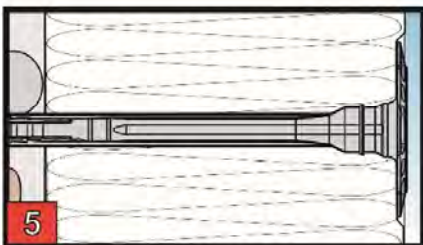

Surface-flush mounted

Insulation support • TSBD • TSBD X • TSBDL • TSBD WS • TSBD WSG

**Intended Use**

Installation instructions TSBD - surface-flush mounted

Annex B 3

### Installation instructions TSBD X / TSBDL surface-flush mounted

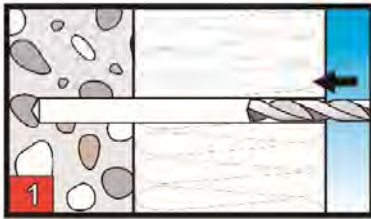

Create a hole about observation of the drill method according Annex C 1

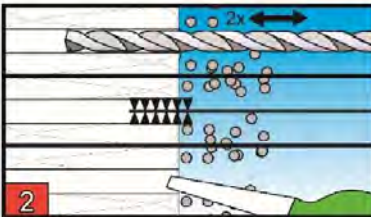

Holes to be cleaned of drilling dust.

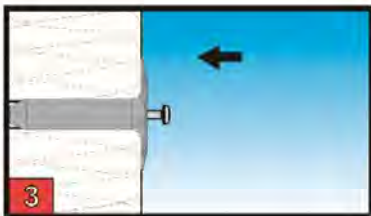

Insert the anchor into the hole until the plate rests on the insulation.

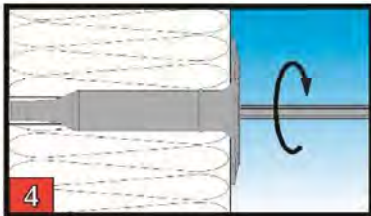

Set the screw with the matching bit

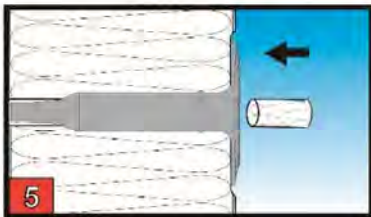

Close the anchor with Anchor cap I or Anchor cap II or foam



Surface-flush mounted

Insulation support • TSBD • TSBD X • TSBDL • TSBD WS • TSBD WSG

**Intended Use**

Installation instructions TSBD X / TSBDL - surface-flush mounted

Annex B 4

### Installation instructions TSBD deepened mounted

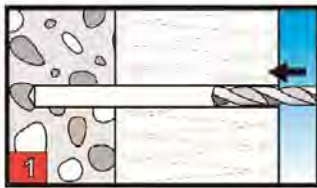

Create a hole about observation of the drill method according Annex C 1

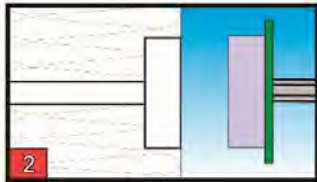

Introduce the indentation in the insulation

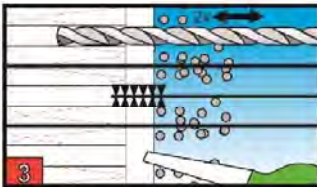

Holes to be cleaned of drilling dust.

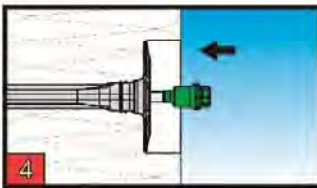

Insert the anchor into the hole until the plate rests on the insulation.

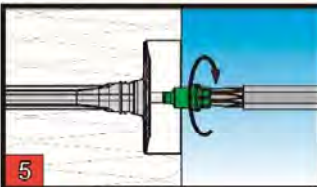

Set the screw with the matching bit

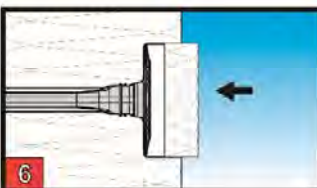

Put the Insulation cover into the insulation

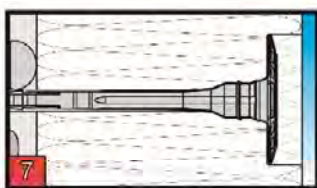

Deepened mounted

Insulation support • TSBD • TSBD X • TSBDL • TSBD WS • TSBD WSG

**Intended Use**

Installation instructions TSBD - deepened mounted

Annex B 5

### Installation instructions TSBd X / TSBdL deepened mounted

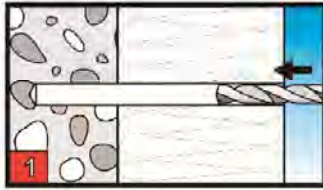

Create a hole about observation of the drill method according Annex C 1

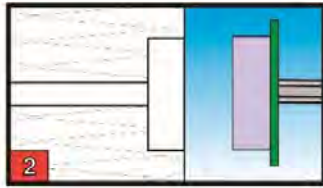

Introduce the indentation in the insulation

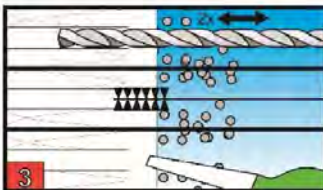

Holes to be cleaned of drilling dust.



Insert the anchor into the hole until the plate rests on the insulation.

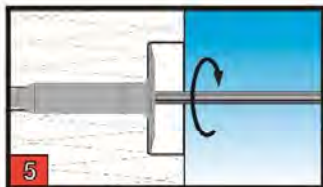

Set the screw with the matching bit

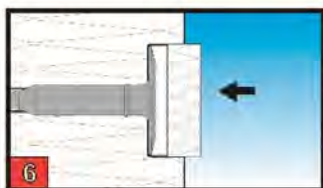

Put the Insulation cover into the insulation

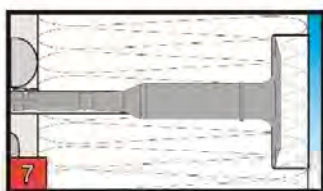

Deepened mounted

Insulation support • TSBd • TSBd X • TSBdL • TSBd WS • TSBd WSG

**Intended Use**

Installation instructions TSBd X / TSBdL - deepened mounted

Annex B 6

**Table C1: Characteristic resistance  $N_{Rk}$  in concrete and masonry for a single anchor in kN**

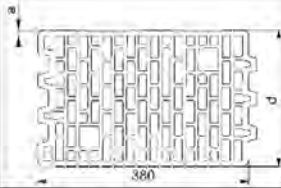
Base material	Bulk-density	Compressive strength	Remarks	Drill method	$N_{Rk}$
	$\rho$ [kg/dm <sup>3</sup> ]	$f_b$ [N/mm <sup>2</sup> ]			[kN]
Concrete C12/15			EN 206-1:2000	Hammer drilling	1,5
Concrete C16/20 – C50/60			EN 206-1:2000		1,5
Sand-lime solid bricks, KS e.g. acc. to EN 771-2:2011	≥1.8	12	Vertically perforation up to 15%		1,5
Brick, Mz e.g. acc. to EN 771-1:2011	≥1.7	12	Vertically perforation up to 15%		1,5
Lightweight concrete solid blocks, Vbl 2 e.g. acc. to EN 771-3:2011	≥0.8	2	with outer web thickness ≥ 43 mm		0,75
Lightweight concrete solid blocks, Vbl 4 e.g. acc. to EN 771-3:2011	≥0.8	4	with outer web thickness ≥ 43 mm		1,2
Vertically perforated clay bricks, HLZ e.g. acc. to EN 771-1:2011 with outer web thickness ≥ 12 mm	≥1.0	12	Vertically perforation more than 15% and less than 50%	Rotary drilling	0,9
Vertically perforated sand-lime bricks, KS L e.g. acc. to EN 771-2:2011 with outer web thickness ≥ 20 mm	≥1.4	12	Vertically perforation more than 15% and less than 50%		1,5
Lightweight concrete hollow blocks 4K Hbl e.g. acc. to EN 771-3:2011	≥0.9	2	with outer web thickness ≥ 30 mm		0,75
Lightweight concrete hollow blocks 1K Hbl e.g. acc. to EN 771-3:2011	≥0.8	2	with outer web thickness ≥ 30 mm		0,9
Vertically perforated clay bricks Hlz 250x380x235 d = 250 mm with outer web thickness a ≥ 16 mm	≥1.0	6			0,5
Lightweight aggregate concrete, LAC 4 e.g. acc. to EN 1520:2011 / EN 771-3:2011	≥1.0	4	$h_{ef} \geq 30\text{mm}$	Hammer drilling	0,4
			$h_{ef} \geq 50\text{mm}$		0,9
Lightweight aggregate concrete, LAC 6 e.g. acc. to EN 1520:2011 / EN 771-3:2011	≥1.0	6	$h_{ef} \geq 30\text{mm}$		0,5
			$h_{ef} \geq 50\text{mm}$		1,2
Autoclaved aerated concrete PP4-0,5 e.g. acc. to EN 771-4:2011	≥0.5	4	$h_{ef} \geq 30\text{mm}$	Rotary drilling	0,30
			$h_{ef} \geq 50\text{mm}$		0,75

**Insulation support •TSBD • TSBD X • TSB DL • TSBD WS • TSBD WSG**

**Performances**  
Characteristic tension resistance of the anchor

Annex C 1

**Table C2: Displacements**

Base material	Bulk-density $\rho$ [kg/dm <sup>3</sup> ]	Compressive Strength $f_b$ [N/mm <sup>2</sup> ]	Tension load <b>N</b> [kN]	Displacements
				$\delta_m(N)$ [mm]
Concrete C12/15-C50/60 EN 206-1:2000			0,50	0,2
Sand-lime solid bricks, KS e.g. acc. to EN 771-2:2011	$\geq 1.8$	12	0,50	0,3
Solid clay brick, Mz e.g. acc. to EN 771-1:2011	$\geq 1.7$	12	0,50	0,3
Lightweight concrete solid blocks, Vbl 2 e.g. acc. to EN 771-3:2011	$\geq 0.8$	2	0,25	0,3
Lightweight concrete solid blocks, Vbl 4 e.g. acc. to EN 771-3:2011	$\geq 0.8$	4	0,40	0,4
Vertically perforated clay bricks, HLz e.g. acc. to EN 771-1:2011	$\geq 1.0$	12	0,30	0,1
Vertically perforated sand-lime bricks, KS L e.g. acc. to EN 771-2:2011	$\geq 1.4$	12	0,50	0,3
Lightweight concrete hollow blocks 4K Hbl e.g. acc. to EN 771-3:2011	$\geq 0.9$	2	0,25	0,1
Lightweight concrete hollow blocks 1K Hbl e.g. acc. to EN 771-3:2011	$\geq 0.8$	2	0,30	0,2
Vertically perforated clay bricks 250x380x235	$\geq 1.0$	6	0,15	0,1
Lightweight aggregate concrete, LAC 4 e.g. acc. to EN 1520:2011 / EN 771-3:2011	$\geq 1.0$	4	$h_{ef} > 30$ mm: 0,15	0,1
			$h_{ef} \geq 50$ mm: 0,30	0,2
Lightweight aggregate concrete, LAC 6 e.g. acc. to EN 1520:2011 / EN 771-3:2011	$\geq 1.0$	6	$h_{ef} > 30$ mm: 0,15	0,1
			$h_{ef} \geq 50$ mm: 0,40	0,2
Autoclaved aerated concrete PP4-0,5 e.g. acc. to EN 771-4:2011	$\geq 0,5$	4	$h_{ef} > 30$ mm: 0,25	0,01
			$h_{ef} \geq 50$ mm: 0,10	0,15

Insulation support •TSBD • TSBD X • TSBDL • TSBD WS • TSBD WSG

Performances  
Displacements

Annex C 2

**Table C3: Point thermal transmittance according to EOTA Technical Report TR 025:2016-05**

Anchor type	thickness of insulation $h_D$ [mm]	Point thermal transmittance $\chi$ [W/K]
KEW – TSBD With specific screw, galvanized steel	≤150mm	0,003
KEW – TSBD With specific screw, galvanized steel	>150mm	0,002
KEW – TSBD With specific screw, stainless steel	≤150mm	0,002
KEW – TSBD With specific screw, stainless steel	>150mm	0,001

Anchor type	thickness of insulation $h_D$ [mm]	Point thermal transmittance $\chi$ [W/K]
KEW – TSBD + Insulation cover With specific screw, galvanized steel	≤150mm	0,002
KEW – TSBD + Insulation cover With specific screw, galvanized steel	>150mm	0,002
KEW – TSBD + Insulation cover With specific screw, stainless steel	≤150mm	0,001
KEW – TSBD + Insulation cover With specific screw, stainless steel	>150mm	0,001

**Insulation support •TSBD • TSBD X • TSBDL • TSBD WS • TSBD WSG**

**Performances**  
Point thermal transmittance

Annex C 3



Anchor type	thickness of insulation $h_D$ [mm]	Point thermal transmittance $\chi$ [W/K]
KEW – TSBD X With specific screw, galvanized steel	≤80mm	0,002
KEW – TSBD X With specific screw, galvanized steel	>80mm	0,001
KEW – TSBD X With specific screw, stainless steel	≤240mm	0,001
KEW – TSBD X With specific screw, stainless steel	>240mm	0,000

Anchor type	thickness of insulation $h_D$ [mm]	Point thermal transmittance $\chi$ [W/K]
KEW – TSBD X + Insulation cover With specific screw, galvanized steel	≤150mm	0,001
KEW – TSBD X + Insulation cover With specific screw, galvanized steel	>150mm	0,001
KEW – TSBD X + Insulation cover With specific screw, stainless steel	≤100mm	0,001
KEW – TSBD X + Insulation cover With specific screw, stainless steel	>100mm	0,000

<b>Insulation support • TSBD • TSBD X • TSBDL • TSBD WS • TSBD WSG</b>		Annex C 4
<b>Performances</b> Point thermal transmittance		

Anchor type	thickness of insulation $h_D$ [mm]	Point thermal transmittance $\chi$ [W/K]
KEW – TSBDL With specific screw, galvanized steel	≤80mm	0,002
KEW – TSBDL With specific screw, galvanized steel	>80mm	0,001
KEW – TSBDL With specific screw, stainless steel	≤240mm	0,001
KEW – TSBDL With specific screw, stainless steel	>240mm	0,000

Anchor type	thickness of insulation $h_D$ [mm]	Point thermal transmittance $\chi$ [W/K]
KEW – TSBDL + Insulation cover With specific screw, galvanized steel	≤150mm	0,001
KEW – TSBDL + Insulation cover With specific screw, galvanized steel	>150mm	0,001
KEW – TSBDL + Insulation cover With specific screw, stainless steel	≤100mm	0,001
KEW – TSBDL + Insulation cover With specific screw, stainless steel	>100mm	0,000

**Table C4: Plate stiffness according to EOTA Technical Report TR 026:2016-05**

Anchor type	Diameter of anchor plates [mm]	Load resistance of anchor plates [kN]	Plate stiffness [kN/mm]
KEW – TSBD	60	2,22	1,6
KEW – TSBD X	60	2,22	1,6
KEW – TSBDL	60	2,22	1,6

<b>Insulation support •TSBD • TSBD X • TSBDL • TSBD WS • TSBD WSG</b>	Annex C 5
<b>Performances</b> Point thermal transmittance, Plate stiffness	